

# VSWD-402 Reverse Alarm

**R10**

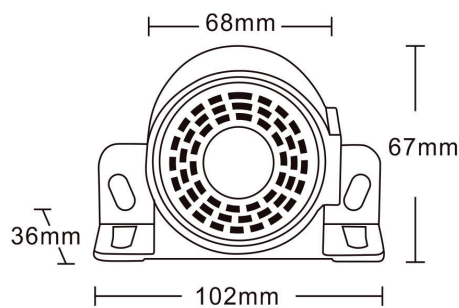
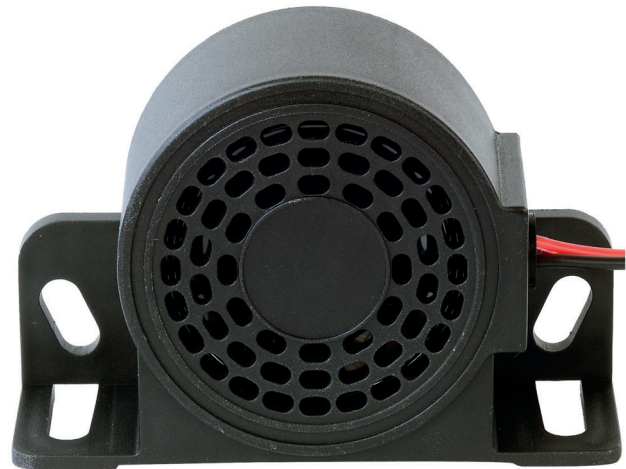

Part Number	Description
VSWD-402-W-97	402 PLUS Alarm 97DB 10-80v 2 SOUNDS NIGHT SILENT 4 WIRES

<b>DB Rating</b>	92-107 dB	<b>Approvals</b>	ECE R10, UKCA
<b>Voltage</b>	12-80v	<b>IP Rating</b>	IP67
<b>Mounting</b>	Bolts, Wires	<b>Additional Features</b>	Night Silent Function
<b>Dimensions</b>	102 x 36 x 67mm	<b>Box Qty</b>	50
<b>Housing Material</b>	ABS	<b>Tone</b>	White Noise & Tonal